



# VSRT-E<sup>®</sup>

Hybrid Gas & Electric  
Vertical Tubeless  
Steam Boilers

9.5 – 60 BHP



The **VSRT-E** combines the industry leading performance of VSRT gas fired steam boilers with zero-emissions electric heating to meet dual-fuel and sustainability goals.



Low NOx  
CERTIFIED



Hybrid  
GAS/ELECTRIC

# THE VSRT-E STEAM BOILER

The highly efficient Fulton VSRT-E steam boiler is ideal for facilities seeking the ultimate flexibility to operate their steam plant on low-emissions natural gas or zero-emissions electrical power.

## ▶ Highest Efficiency

Up to 86% efficiency on natural gas, 99% efficiency on electric operation.

## ▶ Low-to-Zero Emissions

Zero scope 1 emissions when operating on electricity. 20% reduction of CO2 when operating on gas compared to conventional boilers.

## ▶ Built to Last

Long life boiler design and exceptionally durable components reduce overall life cycle resource use.

## ▶ Easy to Operate

Intuitive touchscreen controls enhance energy savings and advance building integration.

## ▶ Low Maintenance Cost

Spiral rib tubeless architecture features a 350% thicker heat exchanger than tubed designs, eliminating the need for costly re-tubing.



# HYBRID GAS & ELECTRIC OPERATION

## ▶ Automated Fuel Switchover

Time-of-day fuel switchover allows the boiler to autonomously take advantage of off-peak electrical rates, simultaneously reducing emissions and lowering energy costs.

## ▶ Future-Proof for Planned Infrastructure

The VSRT-E may be operated exclusively or partially on either gas or electricity while awaiting future infrastructure.

## ▶ Back-Up Energy Source

Fuel curtailment and critical applications that cannot afford downtime may remotely switch between gas and electric operation.

## ▶ Simplicity of Installation

Electricity eliminates costly storage tanks, pumps and vaporization systems required for oil and propane; thereby simplifying the design and reducing points of failure for the utmost peace of mind.

## ▶ Fuel Switching Made Easy

Operations can be switched between gas and electricity via multiple means such as on board touchscreen control, remote contact and BAS communication.

# INDUSTRY LEADING ELECTRIC & GAS FIRING PERFORMANCE

## ▶ Zero Emission Electrical Operation

Operating in electric mode reduces scope 1 emissions to zero.

## ▶ High Efficiency

Fully submerged INCOLY 800 elements deliver direct heating; eliminating stack and purge losses with up to 99% efficiency.

## ▶ Near-Infinite Turndown

Precision Load Matching control; available SCR option offers near-infinite turndown.

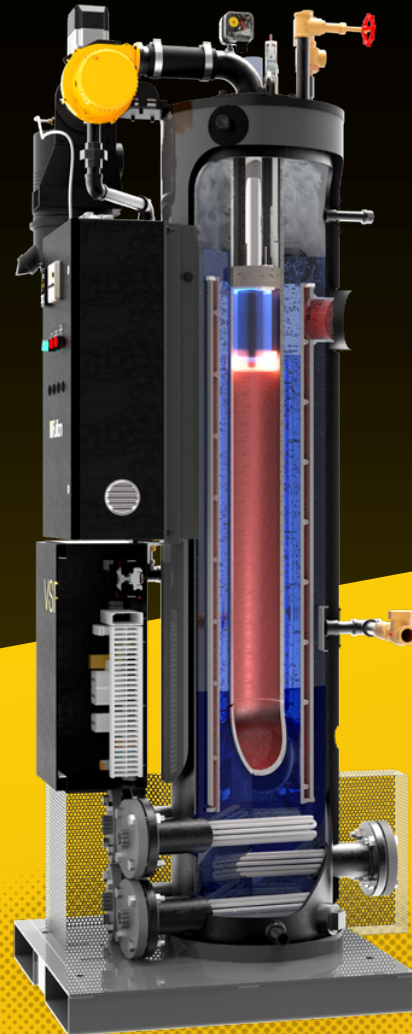
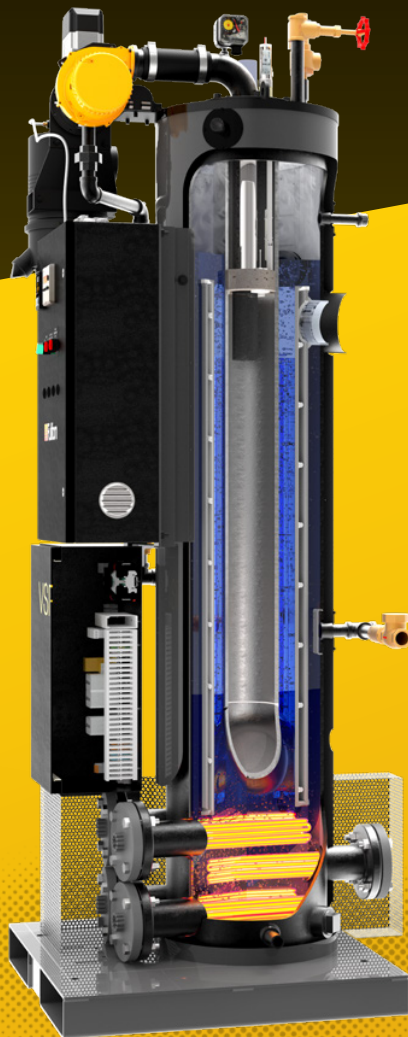

## ▶ Up to 86% Operating Efficiency on Gas

Advanced heat exchanger incorporating variable speed blower with parallel positioning controls provide up to 86% efficiency.

## ▶ High Turndown Burner

Enhanced load matching and significantly reduced cycling with up to 10:1 burner turndown.

## ▶ Ultra Low NOx Emissions

<9 ppm NOx configurable on natural gas; a 90% reduction compared to traditional burners.

# SPECIFICATIONS & DIMENSIONS\*

MODEL: VSRT-E		9.5	40	50	60
<b>GAS</b>					
Boiler Output	(HP)	9.5	40	50	60
Boiler Output	(lbs./hr.)	328	1380	1725	2070
Gas Input	MBH	399	1600	1993	2400
Gas Burner Turndown		8:1	6:1	8:1	10:1
<b>ELECTRIC</b>					
Boiler Output	(kW)	95	405	500	610
Boiler Output	(lbs./hr.)	332.5	1417.5	1750	2135
# of Stages		5	9	9	9
460V 3Ph Amps		124	510	630	768
575V 3Ph Amps		96	407	503	613
<b>DIMENSIONS</b>					
(A) Installed Width (480V)	(in.)	50.125	78.875	78.875	78.875
Minimum Width	(in.)	29	49	49	49
(B) Height	(in.)	95.25	124.375	127.375	124.375
(C) Depth	(in.)	42.375	84.125	84.125	84.125
(D) Side Clearance	(in.)	18	18	18	18
(E) Top Clearance	(in.)	15.5	25.125	25.125	25.125
(F) Front Clearance	(in.)	36	22.25	22.25	22.25
(G) Rear Clearance	(in.)	24	36.125	36.125	36.125

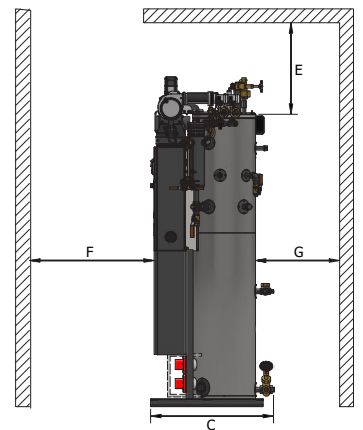
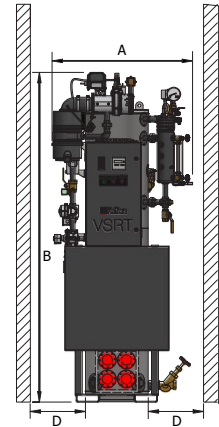

\* Some specification and performance may differ for Australian version of the VSRT-E product range

## ENGINEERED SOLUTIONS

Fulton can design and build a system tailored to your specific needs. Be a part of the process, from concept to delivery, ensuring timely and accurate completion of your engineered system.

- ▶ Industry Leader in Systems Engineering
- ▶ Single-Source Turnkey Systems
- ▶ Wide Range of Ancillary Equipment

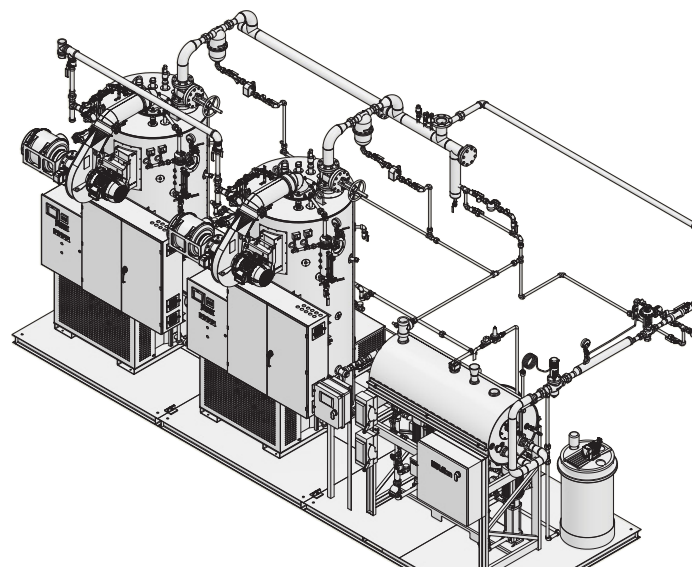

AUSTRALIAN DISTRIBUTORS

**PWS HUNT BOILERS**



Low NOx  
CERTIFIED



IBR BUILDING  
INSTITUTE  
MEMBER



ETL  
Intertek



ASME

\*Listings pending

[fulton.com/vsrte](http://fulton.com/vsrte)

VSRT-E\_BROCHURE\_230711